

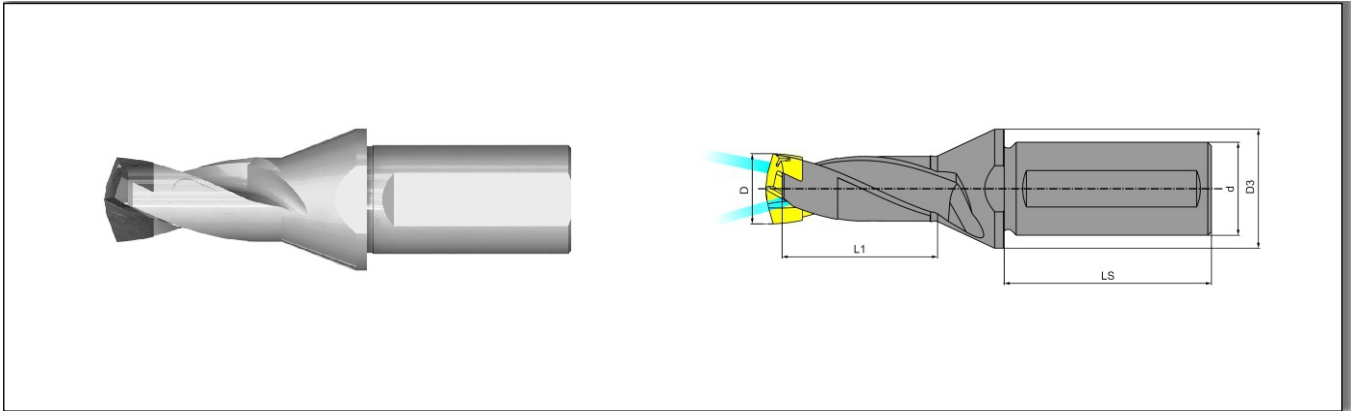







Mono Tip Line Toolholders

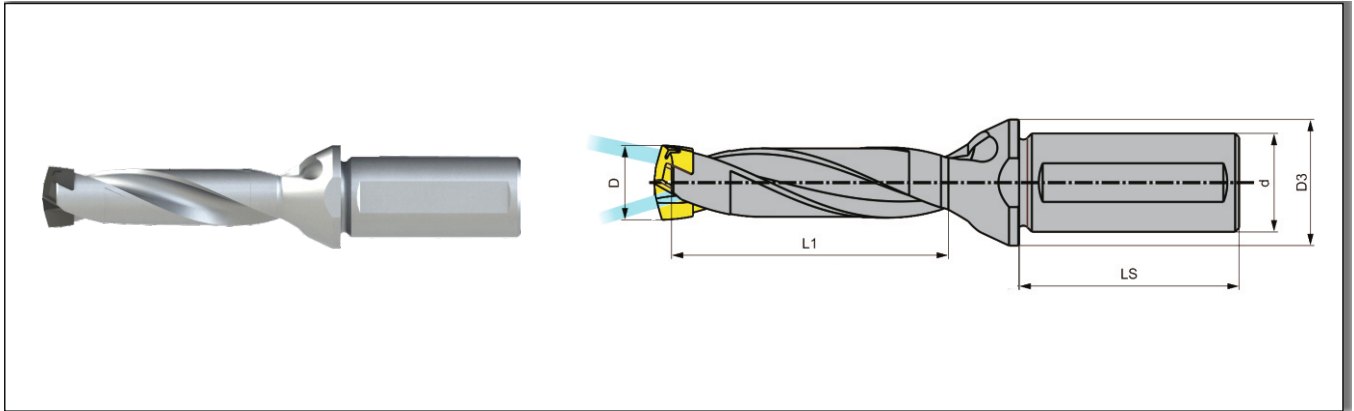

Order No.	Applicable cutting head Dia.(mm)	Dimensions(mm)					Wrench
		d	D3	L1	Ls	D	
QD080/089-12-1.5D-CA	8.0~8.9	12	16	16	45	7.8	8-11.9
QD090/099-12-1.5D-CA	9.0~9.9	12	16	18	45	8.8	
QD100/109-16-1.5D-CA	10.0~10.9	16	20	20	48	9.8	
QD110/119-16-1.5D-CA	11.0~11.9	16	20	22	48	10.8	
QD120/129-16-1.5D-CA	12.0~12.9	16	20	24	48	11.8	12-16.9
QD130/139-16-1.5D-CA	13.0~13.9	16	20	25	48	12.8	
QD140/149-16-1.5D-CA	14.0~14.9	16	20	27	48	13.8	
QD150/159-20-1.5D-CA	15.0~15.9	20	25	29	50	14.8	
QD160/169-20-1.5D-CA	16.0~16.9	20	25	30	50	15.8	17-20.9
QD170/179-20-1.5D-CA	17.0~17.9	20	25	32	50	16.8	
QD180/189-25-1.5D-CA	18.0~18.9	25	32	34	56	17.8	
QD190/199-25-1.5D-CA	19.0~19.9	25	32	36	56	18.8	
QD200/209-25-1.5D-CA	20.0~20.9	25	32	38	56	19.8	21-26
QD210/219-25-1.5D-CA	21.0~21.9	25	32	40	56	20.8	
QD220/229-25-1.5D-CA	22.0~22.9	25	32	42	56	21.8	
QD230/239-32-1.5D-CA	23.0~23.9	32	42	43	60	22.8	
QD240/249-32-1.5D-CA	24.0~24.9	32	42	45	60	23.8	21-26
QD250/260-32-1.5D-CA	25.0~26.0	32	42	47	60	24.8	
inch	inch	inch	mm	mm	mm	mm	
QD5/16-11/32-1/2-1.5D-CA	5/16~11/32	1/2	16	16	45	7.5	8-11.9
QD23/64-25/64-1/2-1.5D-CA	23/64~25/64	1/2	16	18	45	8.8	
QD13/32-27/64-5/8-1.5D-CA	13/32~27/64	5/8	20	20	48	9.9	
QD7/16-15/32-5/8-1.5D-CA	7/16~15/32	5/8	20	22	48	10.7	
QD31/64-1/2-5/8-1.5D-CA	31/64~1/2	5/8	20	24	48	11.9	12-16.9
QD33/64-35/64-1/2-1.5D-CA	33/64~35/64	5/8	20	25	48	12.6	
QD9/16-37/64-1/2-1.5D-CA	9/16~37/64	5/8	25	27	48	13.8	
QD19/32-5/8-3/4-1.5D-CA	19/32~5/8	3/4	25	29	50	14.5	
QD41/64-21/32-3/4-1.5D-CA	41/64~21/32	3/4	25	30	50	15.6	17-20.9
QD43/64-45/64-3/4-1.5D-CA	43/64~45/64	3/4	25	32	50	16.7	
QD23/32-47/64-1-1.5D-CA	23/32~47/64	1	32	34	56	17.6	
QD3/8-25/32-1-1.5D-CA	3/8~25/32	1	32	36	56	18.4	
QD51/64-13/16-1-1.5D-CA	51/64~13/16	1	32	38	56	19.6	21-26
QD53/64-55/64-1-1.5D-CA	53/64~55/64	1	32	40	56	20.4	
QD7/8-57/64-1-1.5D-CA	7/8~57/64	1	32	42	56	21.6	
QD29/32-59/64-1 1/4-1.5D-CA	29/32~59/64	1 1/4	42	43	60	22.4	
QD61/64-31/32-1 1/4-1.5D-CA	61/64~1/32	1 1/4	42	45	60	23.6	21-26
QD63/64-1-1 1/4-1.5D-CA	63/64~1	1 1/4	42	47	60	24.4	



Mono Tip Line Toolholders



Order No.	Applicable cutting head Dia.(mm)	Dimensions(mm)					Wrench
		d	D3	L1	Ls	D	
QD080/089-12-3D-CA	8.0~8.9	12	16	32	45	7.8	8-11.9
QD090/099-12-3D-CA	9.0~9.9	12	16	35	45	8.8	
QD100/109-16-3D-CA	10.0~10.9	16	20	39	48	9.8	
QD110/119-16-3D-CA	11.0~11.9	16	20	42	48	10.8	
QD120/129-16-3D-CA	12.0~12.9	16	20	45	48	11.8	12-16.9
QD130/139-16-3D-CA	13.0~13.9	16	20	49	48	12.8	
QD140/149-16-3D-CA	14.0~14.9	16	20	53	48	13.8	
QD150/159-20-3D-CA	15.0~15.9	20	25	56	50	14.8	
QD160/169-20-3D-CA	16.0~16.9	20	25	60	50	15.8	17-20.9
QD170/179-20-3D-CA	17.0~17.9	20	25	63	50	16.8	
QD180/189-25-3D-CA	18.0~18.9	25	32	66	56	17.8	
QD190/199-25-3D-CA	19.0~19.9	25	32	70	56	18.8	
QD200/209-25-3D-CA	20.0~20.9	25	32	73	56	19.8	21-26
QD210/219-25-3D-CA	21.0~21.9	25	32	77	56	20.8	
QD220/229-25-3D-CA	22.0~22.9	25	32	80	56	21.8	
QD230/239-32-3D-CA	23.0~23.9	32	42	84	60	22.8	
QD240/249-32-3D-CA	24.0~24.9	32	42	88	60	23.8	21-26
QD250/260-32-3D-CA	25.0~26.0	32	42	91	60	24.8	
inch	inch	inch	mm	mm	mm	mm	
QD5/16-11/32-1/2-3D-CA	5/16~11/32	1/2	16	32	45	7.5	8-11.9
QD23/64-25/64-1/2-3D-CA	23/64~25/64	1/2	16	35	45	8.8	
QD13/32-27/64-5/8-3D-CA	13/32~27/64	5/8	20	39	48	9.9	
QD7/16-15/32-5/8-3D-CA	7/16~15/32	5/8	20	42	48	10.7	
QD31/64-1/2-5/8-3D-CA	31/64~1/2	5/8	20	45	48	11.9	12-16.9
QD33/64-35/64-1/2-3D-CA	33/64~35/64	5/8	20	49	48	12.6	
QD9/16-37/64-1/2-3D-CA	9/16~37/64	5/8	25	53	48	13.8	
QD19/32-5/8-3/4-3D-CA	19/32~5/8	3/4	25	56	50	14.5	
QD41/64-21/32-3/4-3D-CA	41/64~21/32	3/4	25	60	50	15.6	17-20.9
QD43/64-45/64-3/4-3D-CA	43/64~45/64	3/4	25	63	50	16.7	
QD23/32-47/64-1-3D-CA	23/32~47/64	1	32	66	56	17.6	
QD3/8-25/32-1-3D-CA	3/8~25/32	1	32	70	56	18.4	
QD51/64-13/16-1-3D-CA	51/64~13/16	1	32	73	56	19.6	21-26
QD53/64-55/64-1-3D-CA	53/64~55/64	1	32	77	56	20.4	
QD7/8-57/64-1-3D-CA	7/8~57/64	1	32	80	56	21.6	
QD29/32-59/64-1 1/4-3D-CA	29/32~59/64	1 1/4	42	84	60	22.4	
QD61/64-31/32-1 1/4-3D-CA	61/64~31/32	1 1/4	42	88	60	23.6	21-26
QD63/64-1-1 1/4-3D-CA	63/64~1	1 1/4	42	91	60	24.4	

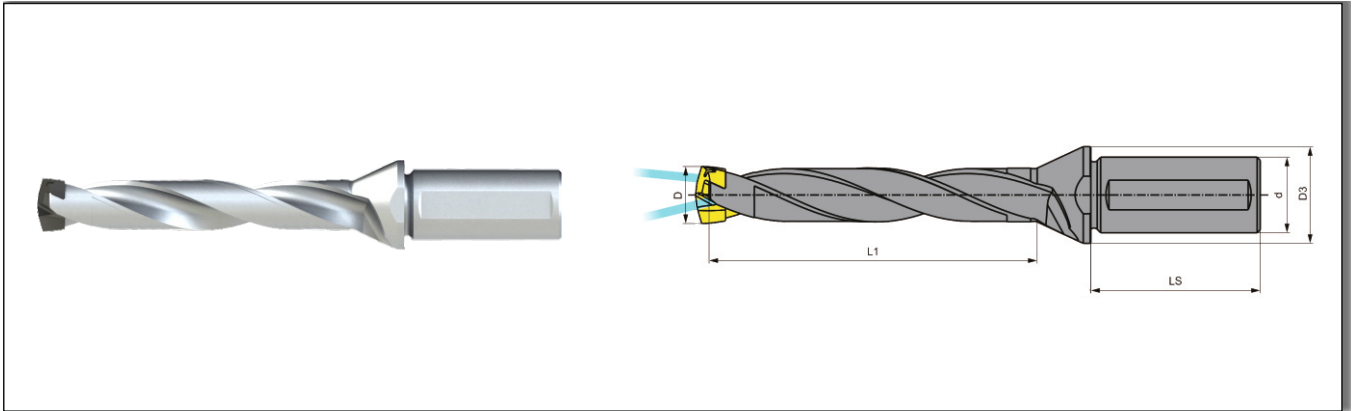

Mono Tip Line Toolholders

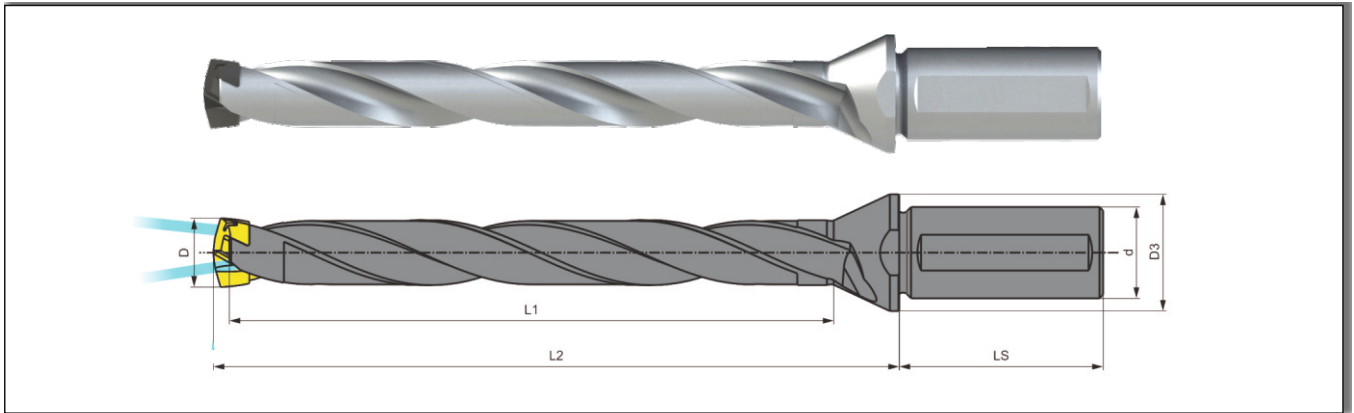

Order No.	Applicable cutting head Dia.(mm)	Dimensions(mm)					Wrench
		d	D3	L1	Ls	D	
QD080/089-12-5D-CA	8.0~8.9	12	16	50	45	7.8	8-11.9
QD090/099-12-5D-CA	9.0~9.9	12	16	55	45	8.8	
QD100/109-16-5D-CA	10.0~10.9	16	20	60	48	9.8	
QD110/119-16-5D-CA	11.0~11.9	16	20	66	48	10.8	12-16.9
QD120/129-16-5D-CA	12.0~12.9	16	20	71	48	11.8	
QD130/139-16-5D-CA	13.0~13.9	16	20	77	48	12.8	
QD140/149-16-5D-CA	14.0~14.9	16	20	82	48	13.8	
QD150/159-20-5D-CA	15.0~15.9	20	25	88	50	14.8	
QD160/169-20-5D-CA	16.0~16.9	20	25	93	50	15.8	17-20.9
QD170/179-20-5D-CA	17.0~17.9	20	25	99	50	16.8	
QD180/189-25-5D-CA	18.0~18.9	25	32	104	56	17.8	
QD190/199-25-5D-CA	19.0~19.9	25	32	110	56	18.8	21-26
QD200/209-25-5D-CA	20.0~20.9	25	32	115	56	19.8	
QD210/219-25-5D-CA	21.0~21.9	25	32	121	56	20.8	
QD220/229-25-5D-CA	22.0~22.9	25	32	126	56	21.8	
QD230/239-32-5D-CA	23.0~23.9	32	42	132	60	22.8	
QD240/249-32-5D-CA	24.0~24.9	32	42	137	60	23.8	21-26
QD250/260-32-5D-CA	25.0~26.0	32	42	143	60	24.8	
inch	inch	inch	mm	mm	mm	mm	
QD5/16-11/32-1/2-5D-CA	5/16~11/32	1/2	16	50	45	7.5	8-11.9
QD23/64-25/64-1/2-5D-CA	23/64~25/64	1/2	16	55	45	8.8	
QD13/32-27/64-5/8-5D-CA	13/32~27/64	5/8	20	60	48	9.9	
QD7/16-15/32-5/8-5D-CA	7/16~15/32	5/8	20	66	48	10.7	12-16.9
QD31/64-1/2-5/8-5D-CA	31/64~1/2	5/8	20	71	48	11.9	
QD33/64-35/64-1/2-5D-CA	33/64~35/64	5/8	20	77	48	12.6	
QD9/16-37/64-1/2-5D-CA	9/16~37/64	5/8	25	82	48	13.8	
QD19/32-5/8-3/4-5D-CA	19/32~5/8	3/4	25	88	50	14.5	
QD41/64-21/32-3/4-5D-CA	41/64~21/32	3/4	25	93	50	15.6	17-20.9
QD43/64-45/64-3/4-5D-CA	43/64~45/64	3/4	25	99	50	16.7	
QD23/32-47/64-1-5D-CA	23/32~47/64	1	32	104	56	17.6	
QD3/8-25/32-1-5D-CA	3/8~25/32	1	32	110	56	18.4	21-26
QD51/64-13/16-1-5D-CA	51/64~13/16	1	32	115	56	19.6	
QD53/64-55/64-1-5D-CA	53/64~55/64	1	32	121	56	20.4	
QD7/8-57/64-1-5D-CA	7/8~57/64	1	32	126	56	21.6	
QD29/32-59/64-1 1/4-5D-CA	29/32~59/64	1 1/4	42	132	60	22.4	
QD61/64-31/32-1 1/4-5D-CA	61/64~1/32	1 1/4	42	137	60	23.6	21-26
QD63/64-1-1 1/4-5D-CA	63/64~1	1 1/4	42	143	60	24.4	

Mono Tip Line Toolholders



Order No.	Applicable cutting head Dia.(mm)	Dimensions(mm)					Wrench
		d	D3	L1	Ls	D	
QD080/089-12-8D-CA	8.0~8.9	12	16	76	45	7.6	8-11.9
QD090/099-12-8D-CA	9.0~9.9	12	16	85	45	8.6	
QD100/109-16-8D-CA	10.0~10.9	16	20	93	48	9.6	
QD110/119-16-8D-CA	11.0~11.9	16	20	102	48	10.6	
QD120/129-16-8D-CA	12.0~12.9	16	20	110	48	11.6	
QD130/139-16-8D-CA	13.0~13.9	16	20	119	48	12.6	
QD140/149-16-8D-CA	14.0~14.9	16	20	127	48	13.6	
QD150/159-20-8D-CA	15.0~15.9	20	25	136	50	14.6	
QD160/169-20-8D-CA	16.0~16.9	20	25	144	50	15.6	17-20.9
QD170/179-20-8D-CA	17.0~17.9	20	25	153	50	16.6	
QD180/189-25-8D-CA	18.0~18.9	25	32	161	56	17.6	
QD190/199-25-8D-CA	19.0~19.9	25	32	170	56	18.6	
QD200/209-25-8D-CA	20.0~20.9	25	32	178	56	19.6	
QD210/219-25-8D-CA	21.0~21.9	25	32	187	56	20.6	
QD220/229-25-8D-CA	22.0~22.9	25	32	195	56	21.6	
QD230/239-32-8D-CA	23.0~23.9	32	42	204	60	22.6	
QD240/249-32-8D-CA	24.0~24.9	32	42	212	60	23.6	
QD250/260-32-8D-CA	25.0~26.0	32	42	221	60	24.6	
inch	inch	inch	mm	mm	mm	mm	
QD5/16-11/32-1/2-8D-CA	5/16~11/32	1/2	16	76	45	7.5	8-11.9
QD23/64-25/64-1/2-8D-CA	23/64~25/64	1/2	16	85	45	8.8	
QD13/32-27/64-5/8-8D-CA	13/32~27/64	5/8	20	93	48	9.9	
QD7/16-15/32-5/8-8D-CA	7/16~15/32	5/8	20	102	48	10.7	
QD31/64-1/2-5/8-8D-CA	31/64~1/2	5/8	20	110	48	11.9	
QD33/64-35/64-1/2-8D-CA	33/64~35/64	5/8	20	119	48	12.6	
QD9/16-37/64-1/2-8D-CA	9/16~37/64	5/8	25	127	48	13.8	
QD19/32-5/8-3/4-8D-CA	19/32~5/8	3/4	25	136	50	14.5	
QD41/64-21/32-3/4-8D-CA	41/64~21/32	3/4	25	144	50	15.6	17-20.9
QD43/64-45/64-3/4-8D-CA	43/64~45/64	3/4	25	153	50	16.7	
QD23/32-47/64-1-8D-CA	23/32~47/64	1	32	161	56	17.6	
QD3/8-25/32-1-8D-CA	3/8~25/32	1	32	170	56	18.4	
QD51/64-13/16-1-8D-CA	51/64~13/16	1	32	178	56	19.6	
QD53/64-55/64-1-8D-CA	53/64~55/64	1	32	187	56	20.4	
QD7/8-57/64-1-8D-CA	7/8~57/64	1	32	195	56	21.6	
QD29/32-59/64-1 1/4-8D-CA	29/32~59/64	1 1/4	42	204	60	22.4	
QD61/64-31/32-1 1/4-8D-CA	61/64~1/32	1 1/4	42	212	60	23.6	
QD63/64-1-1 1/4-8D-CA	63/64~1	1 1/4	42	221	60	24.4	

