

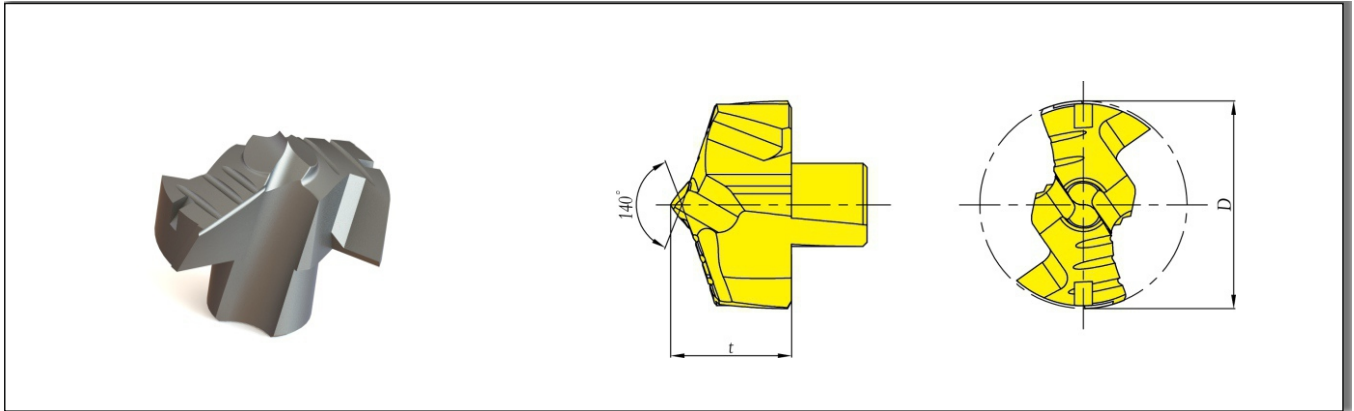



Special Drilling Head RB



Order No.	Dimensions(mm)		tool holders
	D	t	
			
QD-080-RB	8.0	5.4	QD080/089-12-..D-..
QD-081-RB	8.1	5.4	
QD-082-RB	8.2	5.4	
QD-083-RB	8.3	5.4	
QD-084-RB	8.4	5.4	
QD-085-RB	8.5	5.4	
QD-086-RB	8.6	5.4	
QD-087-RB	8.7	5.4	
QD-088-RB	8.8	5.4	
QD-089-RB	8.9	5.4	
QD-090-RB	9.0	5.8	QD090/099-12-..D-..
QD-091-RB	9.1	5.8	
QD-092-RB	9.2	5.8	
QD-093-RB	9.3	5.8	
QD-094-RB	9.4	5.8	
QD-095-RB	9.5	5.8	
QD-096-RB	9.6	5.8	
QD-097-RB	9.7	5.8	
QD-098-RB	9.8	5.8	
QD-099-RB	9.9	5.8	
QD-100-RB	10.0	6.2	QD100/109-16-..D-..
QD-101-RB	10.1	6.2	
QD-102-RB	10.2	6.2	
QD-103-RB	10.3	6.2	
QD-104-RB	10.4	6.2	
QD-105-RB	10.5	6.2	
QD-106-RB	10.6	6.2	
QD-107-RB	10.7	6.2	
QD-108-RB	10.8	6.2	
QD-109-RB	10.9	6.2	

Order No.	Dimensions(mm)		tool holders
	D	t	
			
QD-110-RB	11.0	6.6	QD110/119-16-..D-..
QD-111-RB	11.1	6.6	
QD-112-RB	11.2	6.6	
QD-113-RB	11.3	6.6	
QD-114-RB	11.4	6.6	
QD-115-RB	11.5	6.6	
QD-116-RB	11.6	6.6	
QD-117-RB	11.7	6.6	
QD-118-RB	11.8	6.6	
QD-119-RB	11.9	6.6	
QD-120-RB	12.0	7.0	QD120/129-16-..D-..
QD-121-RB	12.1	7.0	
QD-122-RB	12.2	7.0	
QD-123-RB	12.3	7.0	
QD-124-RB	12.4	7.0	
QD-125-RB	12.5	7.0	
QD-126-RB	12.6	7.0	
QD-127-RB	12.7	7.0	
QD-128-RB	12.8	7.0	
QD-129-RB	12.9	7.0	
QD-130-RB	13.0	7.6	QD130/139-16-..D-..
QD-131-RB	13.1	7.6	
QD-132-RB	13.2	7.6	
QD-133-RB	13.3	7.6	
QD-134-RB	13.4	7.6	
QD-135-RB	13.5	7.6	
QD-136-RB	13.6	7.6	
QD-137-RB	13.7	7.6	
QD-138-RB	13.8	7.6	
QD-139-RB	13.9	7.6	

RB Cutting head can drill with self-centering and less drill force , it can be used for stainless steel ,titanium , nickelbase alloys, Mn steel etc. and other materials not to be broken easily .

Special Drilling Head RB

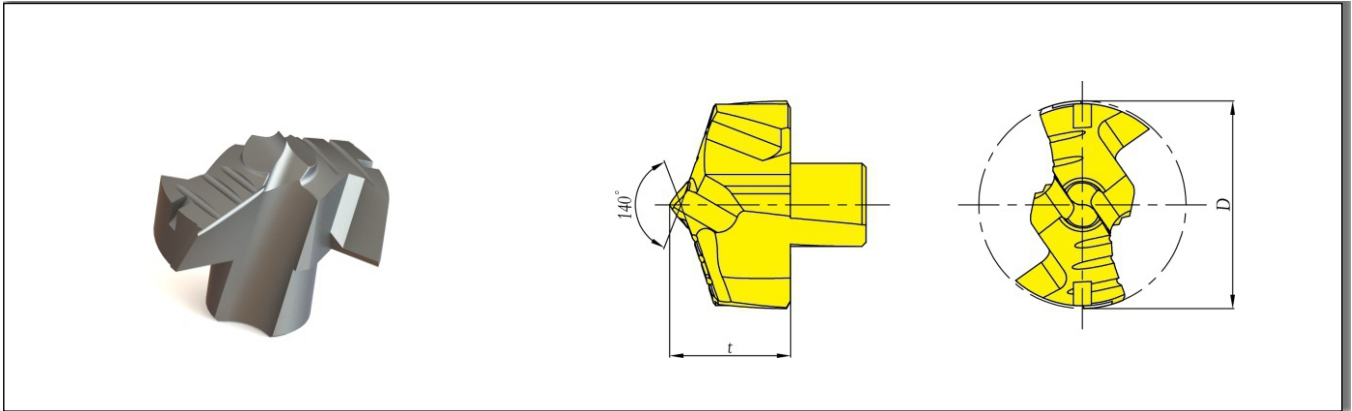

Order No.	Dimensions(mm)		tool holders
	D	t	
QD-140-RB	14.0	8.1	QD140/149-16-..D-..
QD-141-RB	14.1	8.1	
QD-142-RB	14.2	8.1	
QD-143-RB	14.3	8.1	
QD-144-RB	14.4	8.1	
QD-145-RB	14.5	8.1	
QD-146-RB	14.6	8.1	
QD-147-RB	14.7	8.1	
QD-148-RB	14.8	8.1	
QD-149-RB	14.9	8.1	
QD-150-RB	15.0	8.7	QD150/159-20-..D-..
QD-151-RB	15.1	8.7	
QD-152-RB	15.2	8.7	
QD-153-RB	15.3	8.7	
QD-154-RB	15.4	8.7	
QD-155-RB	15.5	8.7	
QD-156-RB	15.6	8.7	
QD-157-RB	15.7	8.7	
QD-158-RB	15.8	8.7	
QD-159-RB	15.9	8.7	
QD-160-RB	16.0	9.3	QD160/169-20-..D-..
QD-161-RB	16.1	9.3	
QD-162-RB	16.2	9.3	
QD-163-RB	16.3	9.3	
QD-164-RB	16.4	9.3	
QD-165-RB	16.5	9.3	
QD-166-RB	16.6	9.3	
QD-167-RB	16.7	9.3	
QD-168-RB	16.8	9.3	
QD-169-RB	16.9	9.3	

Order No.	Dimensions(mm)		tool holders
	D	t	
QD-170-RB	17.0	9.9	QD170/179-20-..D-..
QD-171-RB	17.1	9.9	
QD-172-RB	17.2	9.9	
QD-173-RB	17.3	9.9	
QD-174-RB	17.4	9.9	
QD-175-RB	17.5	9.9	
QD-176-RB	17.6	9.9	
QD-177-RB	17.7	9.9	
QD-178-RB	17.8	9.9	
QD-179-RB	17.9	9.9	
QD-180-RB	18.0	10.5	QD180/189-25-..D-..
QD-181-RB	18.1	10.5	
QD-182-RB	18.2	10.5	
QD-183-RB	18.3	10.5	
QD-184-RB	18.4	10.5	
QD-185-RB	18.5	10.5	
QD-186-RB	18.6	10.5	
QD-187-RB	18.7	10.5	
QD-188-RB	18.8	10.5	
QD-189-RB	18.9	10.5	
QD-190-RB	19.0	11.0	QD190/199-25-..D-..
QD-191-RB	19.1	11.0	
QD-192-RB	19.2	11.0	
QD-193-RB	19.3	11.0	
QD-194-RB	19.4	11.0	
QD-195-RB	19.5	11.0	
QD-196-RB	19.6	11.0	
QD-197-RB	19.7	11.0	
QD-198-RB	19.8	11.0	
QD-199-RB	19.9	11.0	

RB Cutting head can drill with self-centering and less drill force , it can be used for stainless steel ,titanium , nickelbase alloys, Mn steel etc. and other materials not to be broken easily .

Special Drilling Head RB

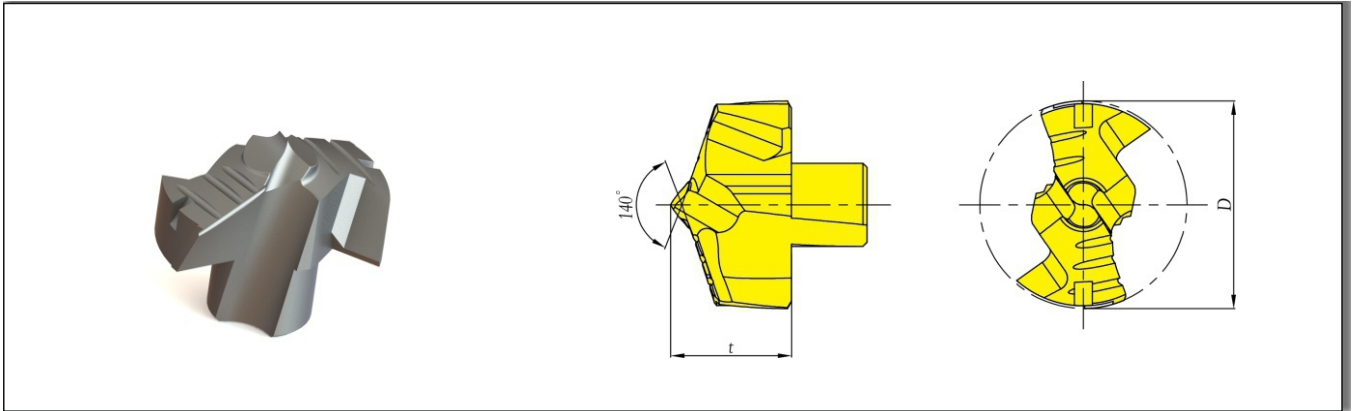

Order No.	Dimensions(mm)		tool holders
	D	t	
QD-200-RB	20.0	11.6	QD200/209-25-..D-..
QD-201-RB	20.1	11.6	
QD-202-RB	20.2	11.6	
QD-203-RB	20.3	11.6	
QD-204-RB	20.4	11.6	
QD-205-RB	20.5	11.6	
QD-206-RB	20.6	11.6	
QD-207-RB	20.7	11.6	
QD-208-RB	20.8	11.6	
QD-209-RB	20.9	11.6	
QD-210-RB	21.0	12.1	QD210/219-25-..D-..
QD-211-RB	21.1	12.1	
QD-212-RB	21.2	12.1	
QD-213-RB	21.3	12.1	
QD-214-RB	21.4	12.1	
QD-215-RB	21.5	12.1	
QD-216-RB	21.6	12.1	
QD-217-RB	21.7	12.1	
QD-218-RB	21.8	12.1	
QD-219-RB	21.9	12.1	
QD-220-RB	22.0	12.7	QD220/229-25-..D-..
QD-221-RB	22.1	12.7	
QD-222-RB	22.2	12.7	
QD-223-RB	22.3	12.7	
QD-224-RB	22.4	12.7	
QD-225-RB	22.5	12.7	
QD-226-RB	22.6	12.7	
QD-227-RB	22.7	12.7	
QD-228-RB	22.8	12.7	
QD-229-RB	22.9	12.7	

Order No.	Dimensions(mm)		tool holders
	D	t	
QD-230-RB	23.0	13.3	QD230/239-32-..D-..
QD-231-RB	23.1	13.3	
QD-232-RB	23.2	13.3	
QD-233-RB	23.3	13.3	
QD-234-RB	23.4	13.3	
QD-235-RB	23.5	13.3	
QD-236-RB	23.6	13.3	
QD-237-RB	23.7	13.3	
QD-238-RB	23.8	13.3	
QD-239-RB	23.9	13.3	
QD-240-RB	24.0	13.9	QD240/249-32-..D-..
QD-241-RB	24.1	13.9	
QD-242-RB	24.2	13.9	
QD-243-RB	24.3	13.9	
QD-244-RB	24.4	13.9	
QD-245-RB	24.5	13.9	
QD-246-RB	24.6	13.9	
QD-247-RB	24.7	13.9	
QD-248-RB	24.8	13.9	
QD-249-RB	24.9	13.9	
QD-250-RB	25.0	14.5	QD250/260-32-..D-..
QD-251-RB	25.1	14.5	
QD-252-RB	25.2	14.5	
QD-253-RB	25.3	14.5	
QD-254-RB	25.4	14.5	
QD-255-RB	25.5	14.5	
QD-256-RB	25.6	14.5	
QD-257-RB	25.7	14.5	
QD-258-RB	25.8	14.5	
QD-259-RB	25.9	14.5	
QD-260-RB	26.0	14.5	

RB Cutting head can drill with self-centering and less drill force , it can be used for stainless steel ,titanium , nickelbase alloys, Mn steel etc. and other materials not to be broken easily .