

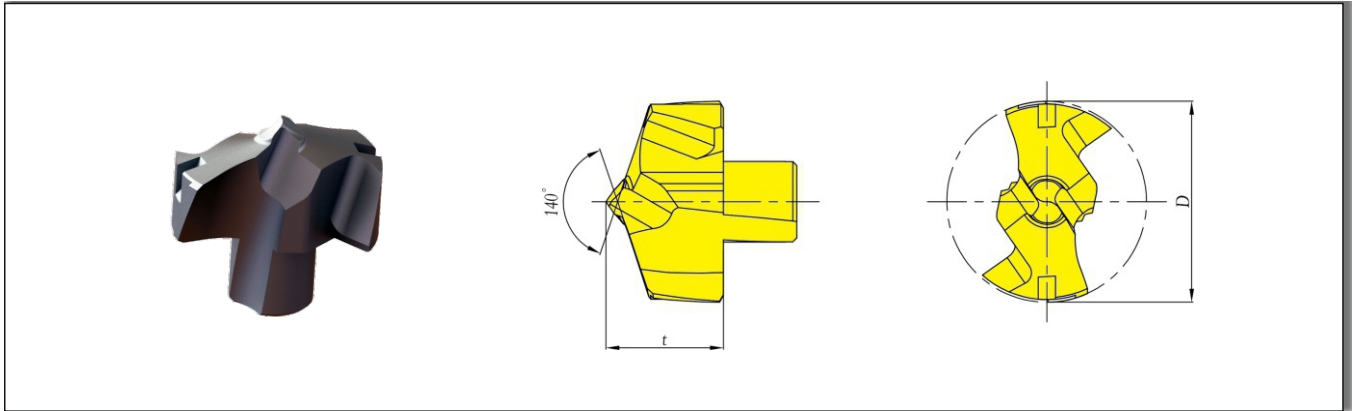



Special Drilling Head RA





Order No.	Dimensions(mm)		tool holders
	D	t	
			
QD-080-RA	8.0	5.4	QD080/089-12-..D-..
QD-081-RA	8.1	5.4	
QD-082-RA	8.2	5.4	
QD-083-RA	8.3	5.4	
QD-084-RA	8.4	5.4	
QD-085-RA	8.5	5.4	
QD-086-RA	8.6	5.4	
QD-087-RA	8.7	5.4	
QD-088-RA	8.8	5.4	
QD-089-RA	8.9	5.4	
QD-090-RA	9.0	5.8	QD090/099-12-..D-..
QD-091-RA	9.1	5.8	
QD-092-RA	9.2	5.8	
QD-093-RA	9.3	5.8	
QD-094-RA	9.4	5.8	
QD-095-RA	9.5	5.8	
QD-096-RA	9.6	5.8	
QD-097-RA	9.7	5.8	
QD-098-RA	9.8	5.8	
QD-099-RA	9.9	5.8	
QD-100-RA	10.0	6.2	QD100/109-16-..D-..
QD-101-RA	10.1	6.2	
QD-102-RA	10.2	6.2	
QD-103-RA	10.3	6.2	
QD-104-RA	10.4	6.2	
QD-105-RA	10.5	6.2	
QD-106-RA	10.6	6.2	
QD-107-RA	10.7	6.2	
QD-108-RA	10.8	6.2	
QD-109-RA	10.9	6.2	

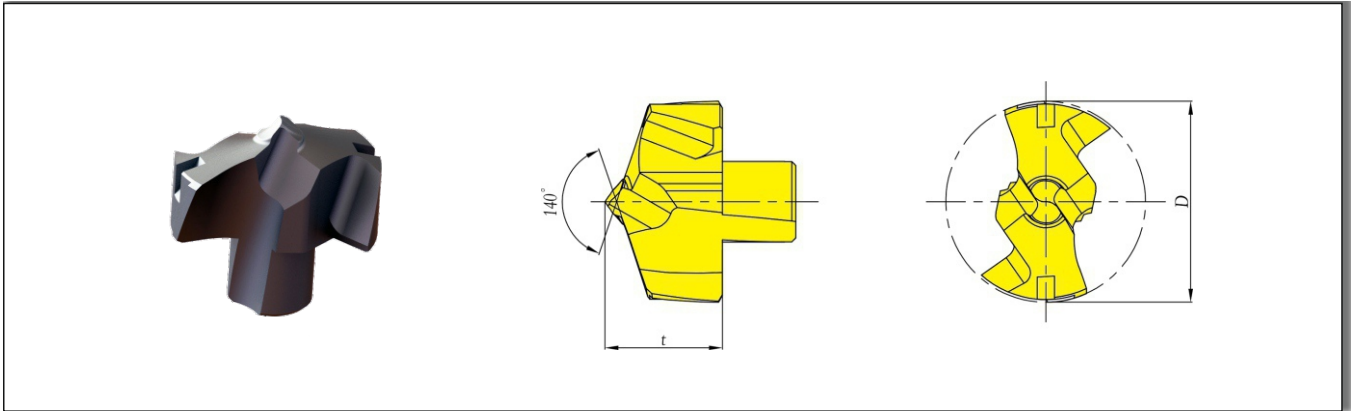

Order No.	Dimensions(mm)		tool holders
	D	t	
			
QD-110-RA	11.0	6.6	QD110/119-16-..D-..
QD-111-RA	11.1	6.6	
QD-112-RA	11.2	6.6	
QD-113-RA	11.3	6.6	
QD-114-RA	11.4	6.6	
QD-115-RA	11.5	6.6	
QD-116-RA	11.6	6.6	
QD-117-RA	11.7	6.6	
QD-118-RA	11.8	6.6	
QD-119-RA	11.9	6.6	
QD-120-RA	12.0	7.0	QD120/129-16-..D-..
QD-121-RA	12.1	7.0	
QD-122-RA	12.2	7.0	
QD-123-RA	12.3	7.0	
QD-124-RA	12.4	7.0	
QD-125-RA	12.5	7.0	
QD-126-RA	12.6	7.0	
QD-127-RA	12.7	7.0	
QD-128-RA	12.8	7.0	
QD-129-RA	12.9	7.0	
QD-130-RA	13.0	7.6	QD130/139-16-..D-..
QD-131-RA	13.1	7.6	
QD-132-RA	13.2	7.6	
QD-133-RA	13.3	7.6	
QD-134-RA	13.4	7.6	
QD-135-RA	13.5	7.6	
QD-136-RA	13.6	7.6	
QD-137-RA	13.7	7.6	
QD-138-RA	13.8	7.6	
QD-139-RA	13.9	7.6	

RA cutting head can drill with self-centering and less drill force and more advantages can be reflected with drilling middle & high carbon , ally steel etc. (espacially for more than 5D)

Special Drilling Head RA





Order No.	Dimensions(mm)		tool holders
	D	t	
			
QD-140-RA	14.0	8.1	QD140/149-16...D-..
QD-141-RA	14.1	8.1	
QD-142-RA	14.2	8.1	
QD-143-RA	14.3	8.1	
QD-144-RA	14.4	8.1	
QD-145-RA	14.5	8.1	
QD-146-RA	14.6	8.1	
QD-147-RA	14.7	8.1	
QD-148-RA	14.8	8.1	
QD-149-RA	14.9	8.1	
QD-150-RA	15.0	8.7	QD150/159-20...D-..
QD-151-RA	15.1	8.7	
QD-152-RA	15.2	8.7	
QD-153-RA	15.3	8.7	
QD-154-RA	15.4	8.7	
QD-155-RA	15.5	8.7	
QD-156-RA	15.6	8.7	
QD-157-RA	15.7	8.7	
QD-158-RA	15.8	8.7	
QD-159-RA	15.9	8.7	
QD-160-RA	16.0	9.3	QD160/169-20...D-..
QD-161-RA	16.1	9.3	
QD-162-RA	16.2	9.3	
QD-163-RA	16.3	9.3	
QD-164-RA	16.4	9.3	
QD-165-RA	16.5	9.3	
QD-166-RA	16.6	9.3	
QD-167-RA	16.7	9.3	
QD-168-RA	16.8	9.3	
QD-169-RA	16.9	9.3	

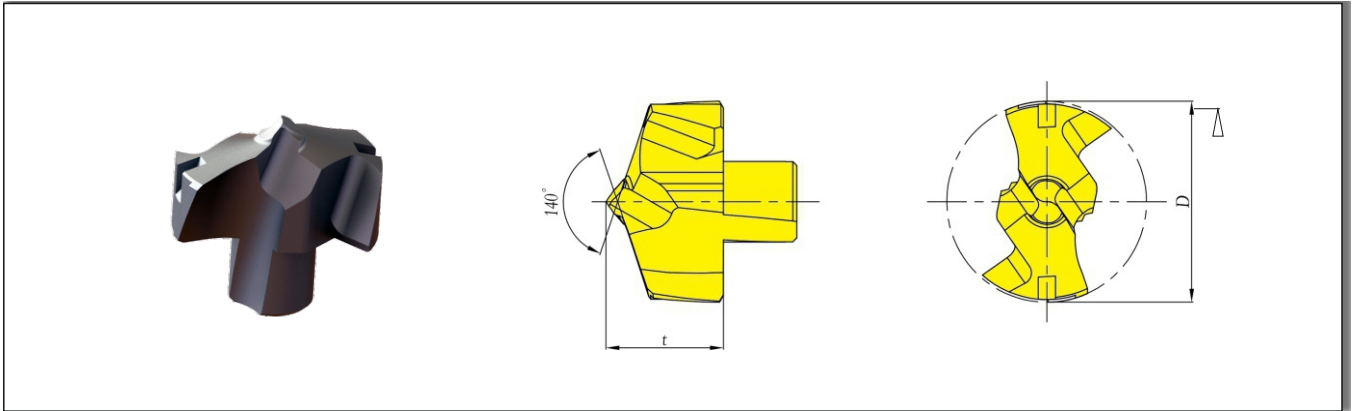

Order No.	Dimensions(mm)		tool holders
	D	t	
			
QD-170-RA	17.0	9.9	QD170/179-20...D-..
QD-171-RA	17.1	9.9	
QD-172-RA	17.2	9.9	
QD-173-RA	17.3	9.9	
QD-174-RA	17.4	9.9	
QD-175-RA	17.5	9.9	
QD-176-RA	17.6	9.9	
QD-177-RA	17.7	9.9	
QD-178-RA	17.8	9.9	
QD-179-RA	17.9	9.9	
QD-180-RA	18.0	10.5	QD180/189-25...D-..
QD-181-RA	18.1	10.5	
QD-182-RA	18.2	10.5	
QD-183-RA	18.3	10.5	
QD-184-RA	18.4	10.5	
QD-185-RA	18.5	10.5	
QD-186-RA	18.6	10.5	
QD-187-RA	18.7	10.5	
QD-188-RA	18.8	10.5	
QD-189-RA	18.9	10.5	
QD-190-RA	19.0	11.0	QD190/199-25...D-..
QD-191-RA	19.1	11.0	
QD-192-RA	19.2	11.0	
QD-193-RA	19.3	11.0	
QD-194-RA	19.4	11.0	
QD-195-RA	19.5	11.0	
QD-196-RA	19.6	11.0	
QD-197-RA	19.7	11.0	
QD-198-RA	19.8	11.0	
QD-199-RA	19.9	11.0	

RA cutting head can drill with self-centering and less drill force and more advantages can be reflected with drilling middle & high carbon , ally steel etc. (espacially for more than 5D)

Special Drilling Head RA





Order No.	Dimensions(mm)		tool holders
	D	t	
			
QD-200-RA	20.0	11.6	QD200/209-25-..D-..
QD-201-RA	20.1	11.6	
QD-202-RA	20.2	11.6	
QD-203-RA	20.3	11.6	
QD-204-RA	20.4	11.6	
QD-205-RA	20.5	11.6	
QD-206-RA	20.6	11.6	
QD-207-RA	20.7	11.6	
QD-208-RA	20.8	11.6	
QD-209-RA	20.9	11.6	
QD-210-RA	21.0	12.1	QD210/219-25-..D-..
QD-211-RA	21.1	12.1	
QD-212-RA	21.2	12.1	
QD-213-RA	21.3	12.1	
QD-214-RA	21.4	12.1	
QD-215-RA	21.5	12.1	
QD-216-RA	21.6	12.1	
QD-217-RA	21.7	12.1	
QD-218-RA	21.8	12.1	
QD-219-RA	21.9	12.1	
QD-220-RA	22.0	12.7	QD220/229-25-..D-..
QD-221-RA	22.1	12.7	
QD-222-RA	22.2	12.7	
QD-223-RA	22.3	12.7	
QD-224-RA	22.4	12.7	
QD-225-RA	22.5	12.7	
QD-226-RA	22.6	12.7	
QD-227-RA	22.7	12.7	
QD-228-RA	22.8	12.7	
QD-229-RA	22.9	12.7	

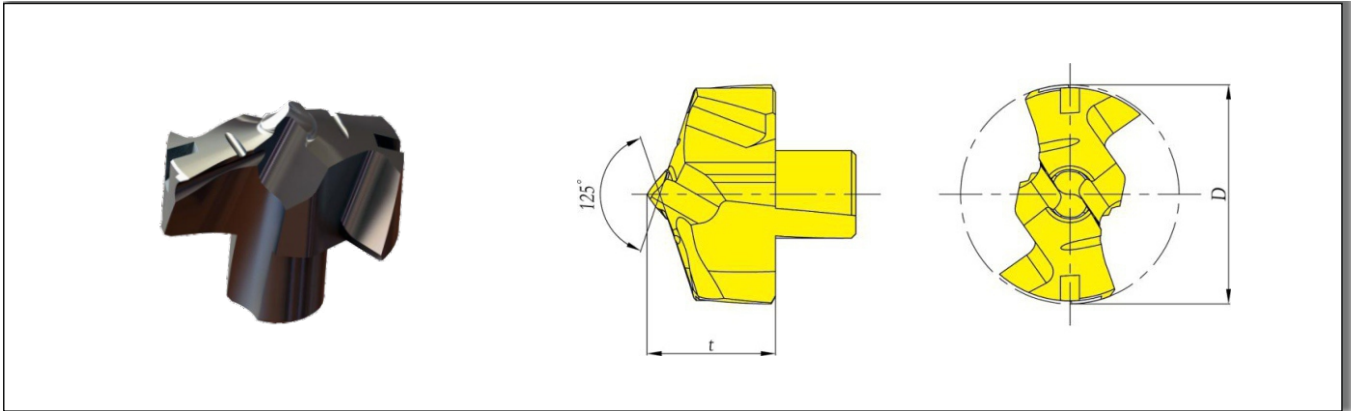

Order No.	Dimensions(mm)		tool holders
	D	t	
			
QD-230-RA	23.0	13.3	QD230/239-32-..D-..
QD-231-RA	23.1	13.3	
QD-232-RA	23.2	13.3	
QD-233-RA	23.3	13.3	
QD-234-RA	23.4	13.3	
QD-235-RA	23.5	13.3	
QD-236-RA	23.6	13.3	
QD-237-RA	23.7	13.3	
QD-238-RA	23.8	13.3	
QD-239-RA	23.9	13.3	
QD-240-RA	24.0	13.9	QD240/249-32-..D-..
QD-241-RA	24.1	13.9	
QD-242-RA	24.2	13.9	
QD-243-RA	24.3	13.9	
QD-244-RA	24.4	13.9	
QD-245-RA	24.5	13.9	
QD-246-RA	24.6	13.9	
QD-247-RA	24.7	13.9	
QD-248-RA	24.8	13.9	
QD-249-RA	24.9	13.9	
QD-250-RA	25.0	14.5	QD250/260-32-..D-..
QD-251-RA	25.1	14.5	
QD-252-RA	25.2	14.5	
QD-253-RA	25.3	14.5	
QD-254-RA	25.4	14.5	
QD-255-RA	25.5	14.5	
QD-256-RA	25.6	14.5	
QD-257-RA	25.7	14.5	
QD-258-RA	25.8	14.5	
QD-259-RA	25.9	14.5	
QD-260-RA	26.0	14.5	

RA cutting head can drill with self-centering and less drill force and more advantages can be reflected with drilling middle & high carbon , ally steel etc. (espacially for more than 5D)

Special Drilling Head RD





Order No.	Dimensions(mm)		tool holders
	D	t	
			
QD-080-RD	8.0	5.4	QD080/089-12-..D-..
QD-081-RD	8.1	5.4	
QD-082-RD	8.2	5.4	
QD-083-RD	8.3	5.4	
QD-084-RD	8.4	5.4	
QD-085-RD	8.5	5.4	
QD-086-RD	8.6	5.4	
QD-087-RD	8.7	5.4	
QD-088-RD	8.8	5.4	
QD-089-RD	8.9	5.4	
QD-090-RD	9.0	5.8	QD090/099-12-..D-..
QD-091-RD	9.1	5.8	
QD-092-RD	9.2	5.8	
QD-093-RD	9.3	5.8	
QD-094-RD	9.4	5.8	
QD-095-RD	9.5	5.8	
QD-096-RD	9.6	5.8	
QD-097-RD	9.7	5.8	
QD-098-RD	9.8	5.8	
QD-099-RD	9.9	5.8	
QD-100-RD	10.0	6.2	QD100/109-16-..D-..
QD-101-RD	10.1	6.2	
QD-102-RD	10.2	6.2	
QD-103-RD	10.3	6.2	
QD-104-RD	10.4	6.2	
QD-105-RD	10.5	6.2	
QD-106-RD	10.6	6.2	
QD-107-RD	10.7	6.2	
QD-108-RD	10.8	6.2	
QD-109-RD	10.9	6.2	

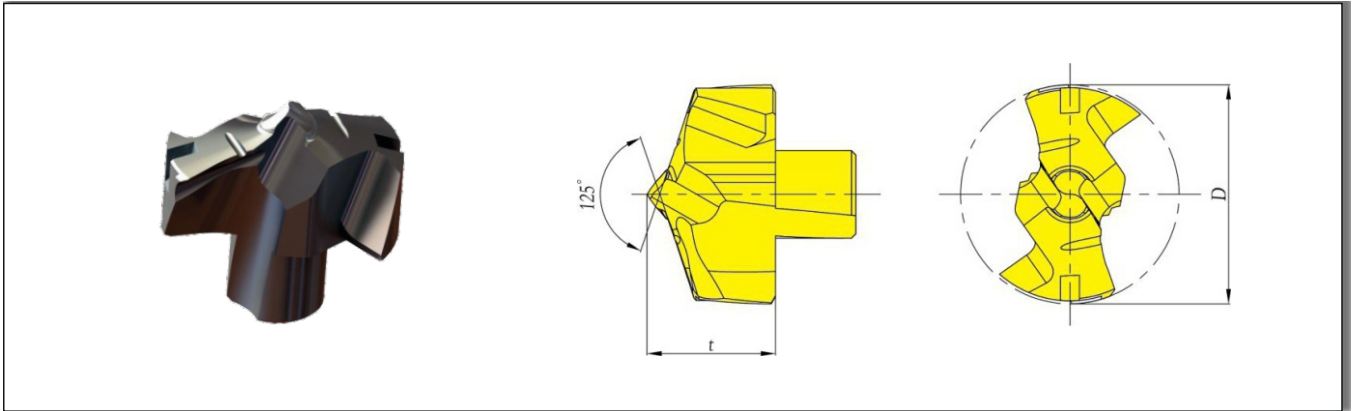

Order No.	Dimensions(mm)		tool holders
	D	t	
			
QD-110-RD	11.0	6.6	QD110/119-16-..D-..
QD-111-RD	11.1	6.6	
QD-112-RD	11.2	6.6	
QD-113-RD	11.3	6.6	
QD-114-RD	11.4	6.6	
QD-115-RD	11.5	6.6	
QD-116-RD	11.6	6.6	
QD-117-RD	11.7	6.6	
QD-118-RD	11.8	6.6	
QD-119-RD	11.9	6.6	
QD-120-RD	12.0	7.0	QD120/129-16-..D-..
QD-121-RD	12.1	7.0	
QD-122-RD	12.2	7.0	
QD-123-RD	12.3	7.0	
QD-124-RD	12.4	7.0	
QD-125-RD	12.5	7.0	
QD-126-RD	12.6	7.0	
QD-127-RD	12.7	7.0	
QD-128-RD	12.8	7.0	
QD-129-RD	12.9	7.0	
QD-130-RD	13.0	7.6	QD130/139-16-..D-..
QD-131-RD	13.1	7.6	
QD-132-RD	13.2	7.6	
QD-133-RD	13.3	7.6	
QD-134-RD	13.4	7.6	
QD-135-RD	13.5	7.6	
QD-136-RD	13.6	7.6	
QD-137-RD	13.7	7.6	
QD-138-RD	13.8	7.6	
QD-139-RD	13.9	7.6	

RD Cutting head can drill with self-centering and less drill force , it can be used for stainless steel ,titanium , nickelbase alloys, Mn steel etc. and other materials not to be broken easily .

Special Drilling Head RD





Order No.	Dimensions(mm)		tool holders
	D	t	
			
QD-140-RD	14.0	8.1	QD140/149-16...D-..
QD-141-RD	14.1	8.1	
QD-142-RD	14.2	8.1	
QD-143-RD	14.3	8.1	
QD-144-RD	14.4	8.1	
QD-145-RD	14.5	8.1	
QD-146-RD	14.6	8.1	
QD-147-RD	14.7	8.1	
QD-148-RD	14.8	8.1	
QD-149-RD	14.9	8.1	
QD-150-RD	15.0	8.7	QD150/159-20...D-..
QD-151-RD	15.1	8.7	
QD-152-RD	15.2	8.7	
QD-153-RD	15.3	8.7	
QD-154-RD	15.4	8.7	
QD-155-RD	15.5	8.7	
QD-156-RD	15.6	8.7	
QD-157-RD	15.7	8.7	
QD-158-RD	15.8	8.7	
QD-159-RD	15.9	8.7	
QD-160-RD	16.0	9.3	QD160/169-20...D-..
QD-161-RD	16.1	9.3	
QD-162-RD	16.2	9.3	
QD-163-RD	16.3	9.3	
QD-164-RD	16.4	9.3	
QD-165-RD	16.5	9.3	
QD-166-RD	16.6	9.3	
QD-167-RD	16.7	9.3	
QD-168-RD	16.8	9.3	
QD-169-RD	16.9	9.3	

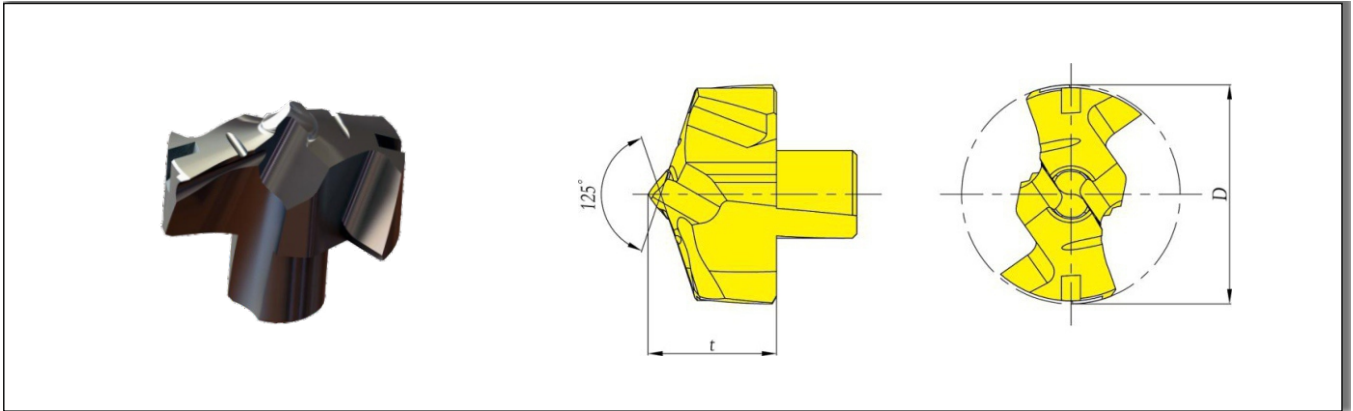

Order No.	Dimensions(mm)		tool holders
	D	t	
			
QD-170-RD	17.0	9.9	QD170/179-20...D-..
QD-171-RD	17.1	9.9	
QD-172-RD	17.2	9.9	
QD-173-RD	17.3	9.9	
QD-174-RD	17.4	9.9	
QD-175-RD	17.5	9.9	
QD-176-RD	17.6	9.9	
QD-177-RD	17.7	9.9	
QD-178-RD	17.8	9.9	
QD-179-RD	17.9	9.9	
QD-180-RD	18.0	10.5	QD180/189-25...D-..
QD-181-RD	18.1	10.5	
QD-182-RD	18.2	10.5	
QD-183-RD	18.3	10.5	
QD-184-RD	18.4	10.5	
QD-185-RD	18.5	10.5	
QD-186-RD	18.6	10.5	
QD-187-RD	18.7	10.5	
QD-188-RD	18.8	10.5	
QD-189-RD	18.9	10.5	
QD-190-RD	19.0	11.0	QD190/199-25...D-..
QD-191-RD	19.1	11.0	
QD-192-RD	19.2	11.0	
QD-193-RD	19.3	11.0	
QD-194-RD	19.4	11.0	
QD-195-RD	19.5	11.0	
QD-196-RD	19.6	11.0	
QD-197-RD	19.7	11.0	
QD-198-RD	19.8	11.0	
QD-199-RD	19.9	11.0	

RD Cutting head can drill with self-centering and less drill force , it can be used for stainless steel ,titanium , nickelbase alloys, Mn steel etc. and other materials not to be broken easily .

Special Drilling Head RD



Order No.	Dimensions(mm)		tool holders
	D	t	
			
QD-200-RD	20.0	11.6	QD200/209-25-..D-..
QD-201-RD	20.1	11.6	
QD-202-RD	20.2	11.6	
QD-203-RD	20.3	11.6	
QD-204-RD	20.4	11.6	
QD-205-RD	20.5	11.6	
QD-206-RD	20.6	11.6	
QD-207-RD	20.7	11.6	
QD-208-RD	20.8	11.6	
QD-209-RD	20.9	11.6	
QD-210-RD	21.0	12.1	QD210/219-25-..D-..
QD-211-RD	21.1	12.1	
QD-212-RD	21.2	12.1	
QD-213-RD	21.3	12.1	
QD-214-RD	21.4	12.1	
QD-215-RD	21.5	12.1	
QD-216-RD	21.6	12.1	
QD-217-RD	21.7	12.1	
QD-218-RD	21.8	12.1	
QD-219-RD	21.9	12.1	
QD-220-RD	22.0	12.7	QD220/229-25-..D-..
QD-221-RD	22.1	12.7	
QD-222-RD	22.2	12.7	
QD-223-RD	22.3	12.7	
QD-224-RD	22.4	12.7	
QD-225-RD	22.5	12.7	
QD-226-RD	22.6	12.7	
QD-227-RD	22.7	12.7	
QD-228-RD	22.8	12.7	
QD-229-RD	22.9	12.7	

Order No.	Dimensions(mm)		tool holders
	D	t	
			
QD-230-RD	23.0	13.3	QD230/239-32-..D-..
QD-231-RD	23.1	13.3	
QD-232-RD	23.2	13.3	
QD-233-RD	23.3	13.3	
QD-234-RD	23.4	13.3	
QD-235-RD	23.5	13.3	
QD-236-RD	23.6	13.3	
QD-237-RD	23.7	13.3	
QD-238-RD	23.8	13.3	
QD-239-RD	23.9	13.3	
QD-240-RD	24.0	13.9	QD240/249-32-..D-..
QD-241-RD	24.1	13.9	
QD-242-RD	24.2	13.9	
QD-243-RD	24.3	13.9	
QD-244-RD	24.4	13.9	
QD-245-RD	24.5	13.9	
QD-246-RD	24.6	13.9	
QD-247-RD	24.7	13.9	
QD-248-RD	24.8	13.9	
QD-249-RD	24.9	13.9	
QD-250-RD	25.0	14.5	QD250/260-32-..D-..
QD-251-RD	25.1	14.5	
QD-252-RD	25.2	14.5	
QD-253-RD	25.3	14.5	
QD-254-RD	25.4	14.5	
QD-255-RD	25.5	14.5	
QD-256-RD	25.6	14.5	
QD-257-RD	25.7	14.5	
QD-258-RD	25.8	14.5	
QD-259-RD	25.9	14.5	
QD-260-RD	26.0	14.5	

RD Cutting head can drill with self-centering and less drill force , it can be used for stainless steel ,titanium , nickelbase alloys, Mn steel etc. and other materials not to be broken easily .